

Industrial Sewing Machines

**K**ansai **S**pecial

# RX SERIES OPERATOR'S MANUAL



MORIMOTO MFG. CO., LTD.

# Table of Contents

1. Safety Instructions	Page 1
------------------------	--------

2. Needles	1-2
------------	-----

- A. Recommendations
- B. Replacement Procedures

3. Threading Instructions	3~5
---------------------------	-----

- A. General Thread Path
- B. Looper Thread Takeup
- C. Cover Thread Takeup
- D. Needle Thread Takeup
- E. Cover Thread Tension

4. Machine Lubrication	5-6
------------------------	-----

- A. Adding The Oil
- B. Changing The Oil
- C. Changing The Oil Filter

5. Handwheel Direction And Operating Speed	7
--	---

- A. Break In Period
- B. Pulley Direction
- C. Machine Speeds And Motor Pulley Sizes

# 1. Safety Instructions

The following must be observed for safety

- Make sure belt cover is installed so as to prevent accidents.
- Only use those electrical parts or components suitable for the voltage in use. The use of incompatible parts or components may lead to excessive heat buildup and eventual burnout.
- Before performing any adjustments or maintenance on the machine, such as cleaning, threading, or replacing the needles, make sure the power is turned off and the motor is not running.
- Always turn the power off when leaving the machine unattended.
- Clean the air filter and discharge the drain of the air regulator on a regular basis. If not done on a regular basis the drain may overflow into the solenoid valve or air cylinder resulting in machine failure.

## 2. Needles

### Recommended Needles:

In order to ensure proper sewing of your RX-Series machines we recommend that you use either Schmetz or Organ brand needles system UY128GAS. Depending on what kind of fabric and thread you are using we suggest the following sizes:

Table 1

Needle System	Needle size					
Schmetz UY128GAS	#65	#70	#75	#80	#85	#90
Organ UY128GAS	# 9	#10	#11	#12	#13	#14

## Replacing Needles:

Please observe the following steps in replacing needles.

### Step 1.

Turn off the switch (1) under the machine table.

**Note:** In the case of a clutch motor being used the motor will continue to rotate due to inertia after the power supply is turned off. If the pedal (2) is stepped on inadvertently the machine will move. Before attempting to replace the needles step on the pedal (2) until the machine comes to a complete stop.

### Step 2.

Loosen screw (3) by using the allen key found in your RX tool kit.

### Step 3.

Remove the old needle using a tweezer.

### Step 4.

Insert the new needle facing its scarf towards the rear of the machine. Refer to Fig. 2-D.

### Step 5.

Refer to Fig 2-E. Make sure the new needle is inserted into the needle hole so that the needle is in as far as it can go.

### Step 6.

Tighten screw (3) by using the allen key.

Fig 1

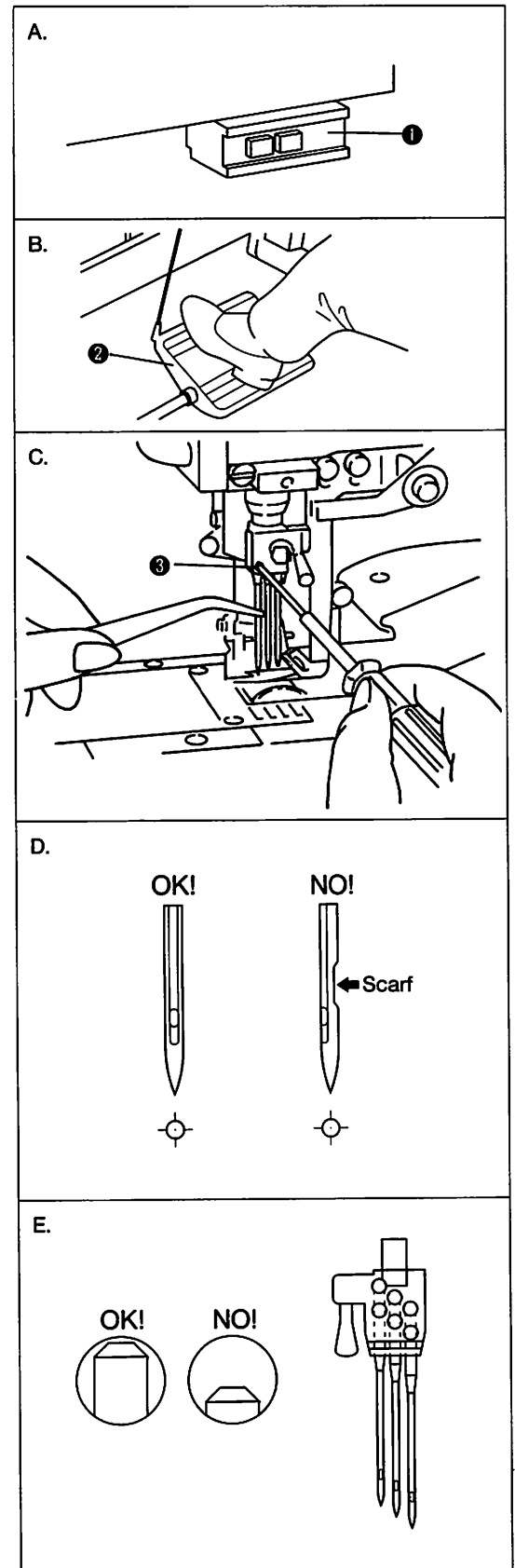

# 3. Threading Instructions

## General Thread Path

Please refer to the diagram below for proper threading of your Kansai Special RX-Series machine. Improper threading will result in poor stitch quality such as skipped stitches, broken threads etc.

A,B,C=Needle Threads

D=Cover Thread

E=Looper Thread

Fig 2

In the case of wooly thread refer to the diagram showing the needle tension moved to bracket above the needle clamp.

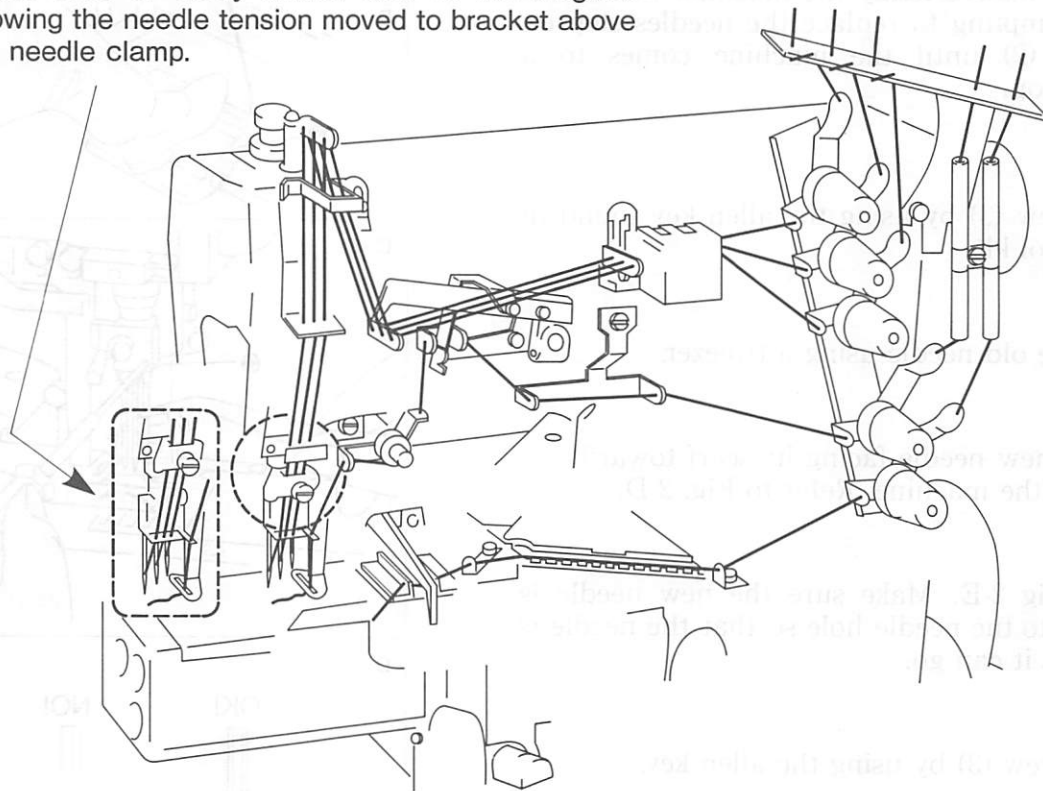

To adjust the cover thread eyelet, loosen screws (D) and adjust to the proper height :  
As the cover thread take up is in its highest position, the bottom of the slot of the cover thread take up is in line with the holes in the cover thread eyelet.

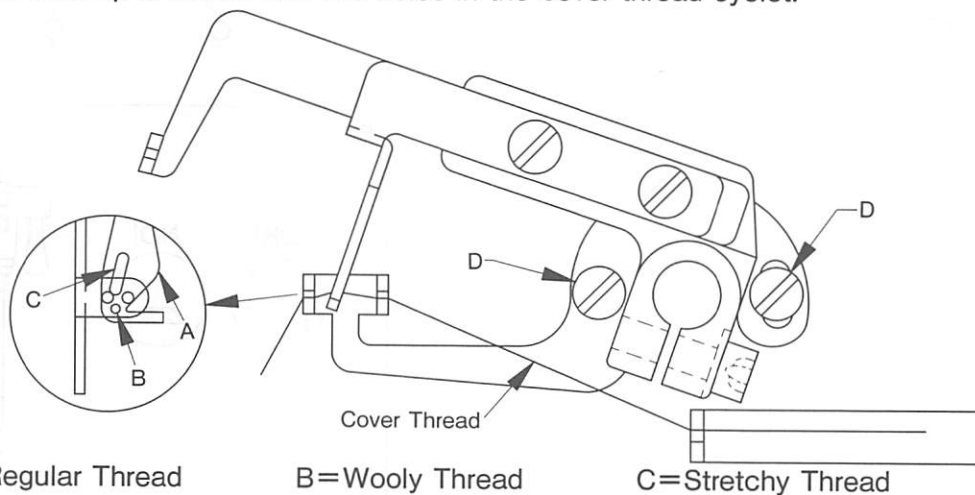

A=Regular Thread

B=Wooly Thread

C=Stretchy Thread

## Looper Thread Takeup

(Refer to Fig3)

When threading the looper thread takeup press the button (3). The bracket (4) will move upwards. After threading replace bracket (4) to its original position by pushing down on the bracket.

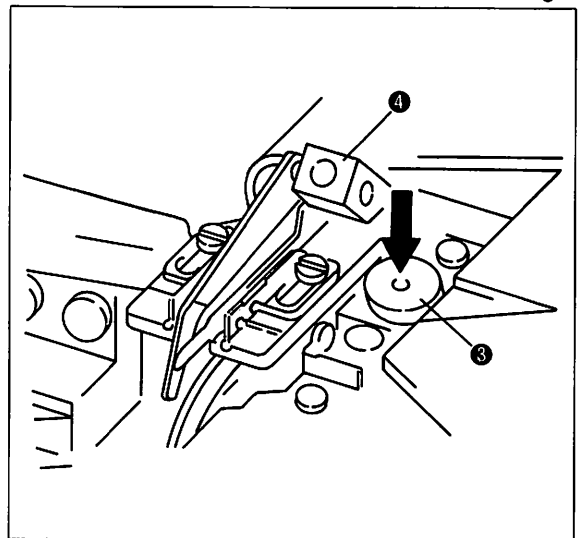

Fig 3

## Cover Thread Takeup

(Refer to Fig4)

When using wooly thread refer to the diagram showing threads (B) & (C). In this situation the cover thread DOES NOT pass through the hole in the takeup. For use with regular thread refer to the diagram showing thread (D) where the thread passes through the hole in the takeup.

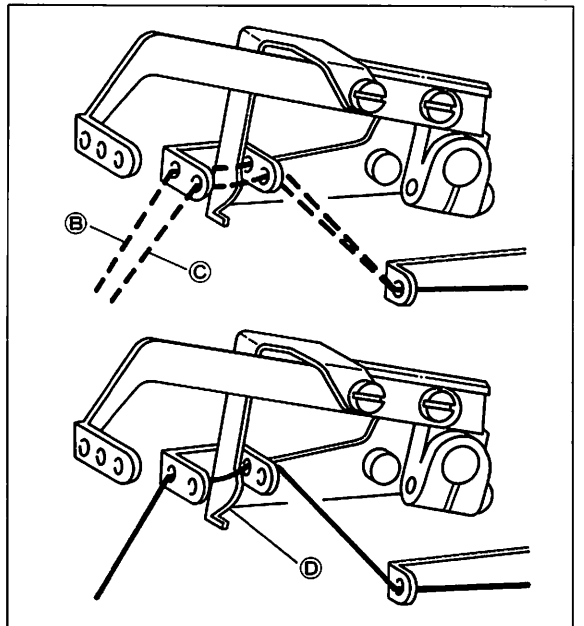

Fig 4

## Needle Thread Take Up

(Refer to Fig5)

When using wooly thread follow the dotted lines marked (A). If regular thread is being used then follow the solid thread lines.

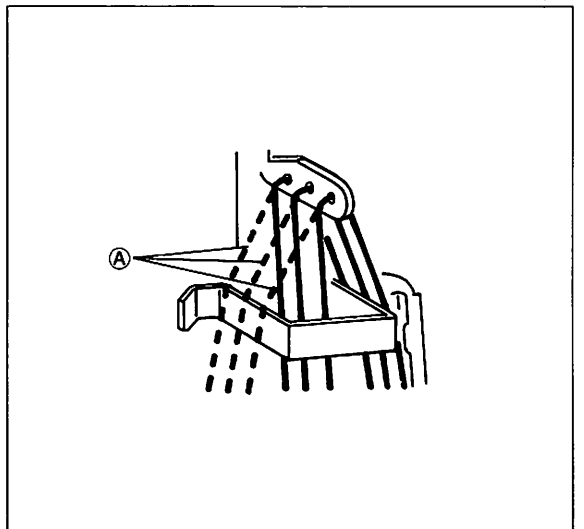

Fig 5

Fig 6

### Cover Thread Tension

(Refer to Fig6)

When using wooly thread refer to dotted line (E) and bypass the spring tension. If regular thread is being used then pass the thread through the spring tension.

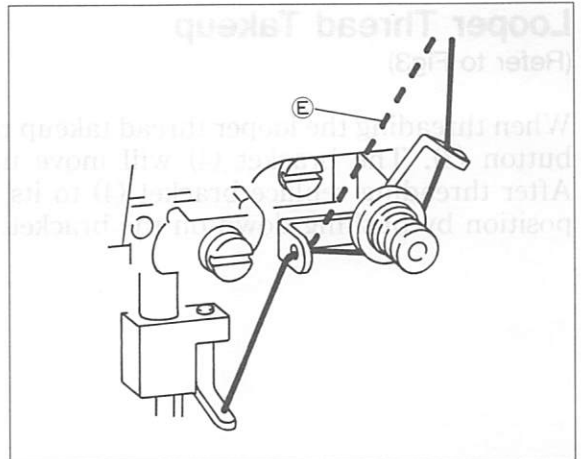

## 4. Machine Lubrication

It is recommended that you use Mobil Velocite Oil No.32.

### Adding The Oil

(Refer to Fig7)

- 1) Before operating the machine fill it with oil. Remove cap (A) and fill with oil. To determine the proper amount of oil check quage (C).
- 2) After filling with oil turn the machine on and step on the foot pedal. Check the window (B) during operation so as to make sure that the oil pump is working correctly.

Fig 7

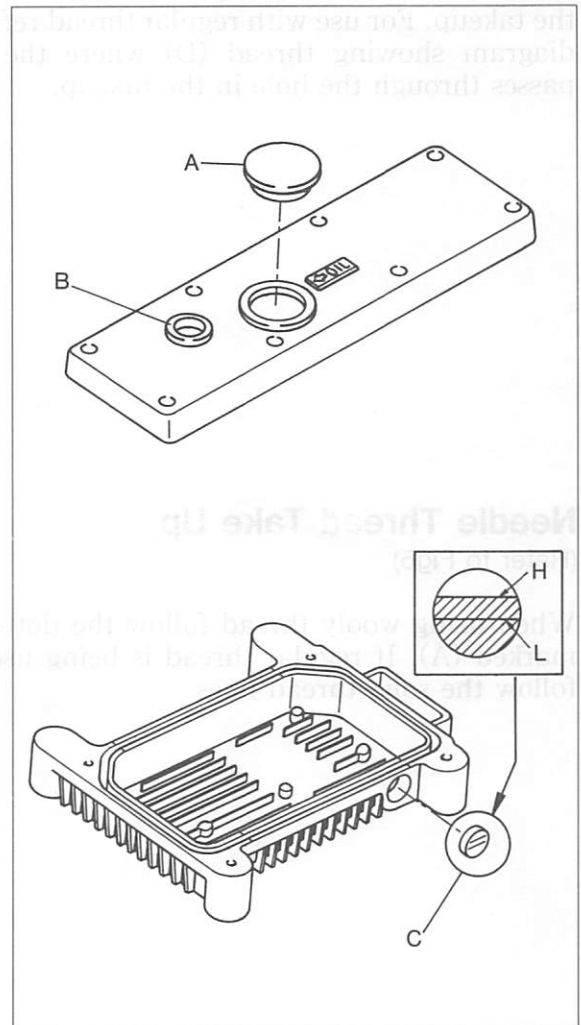

Fig 8

## Changing The Oil

(Refer to Fig8)

After the first 250 hours of operation it is recommended that you drain the old oil out of the machine and replace it with fresh oil.

### Steps

- 1) Make sure that the motor is off.
- 2) Remove the belt from the handwheel.
- 3) Remove the oil plug (D).
- 4) Drain the oil from the machine.
- 5) Reinstall the drainplug and tighten.
- 6) Follow the instructions for filling the machine with oil.

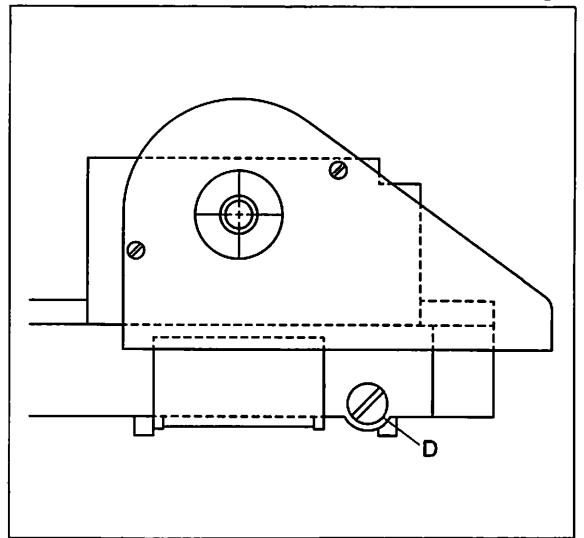

Fig 9

## Changing The Oil Filter

(Refer to Fig9)

### Steps

- 1) After draining the oil from the machine, as described in the previous section, remove cover (F) from the rear of the machine.
- 2) Be careful when removing cover (F) not to misplace seal (O).
- 3) Remove oil filter (E) from the machine.
- 4) Inspect the oil filter and clean or replace it, if necessary.
- 5) Place the filter back into the machine. Do not forget to reinstall seal (O).
- 6) Refill the machine with oil.

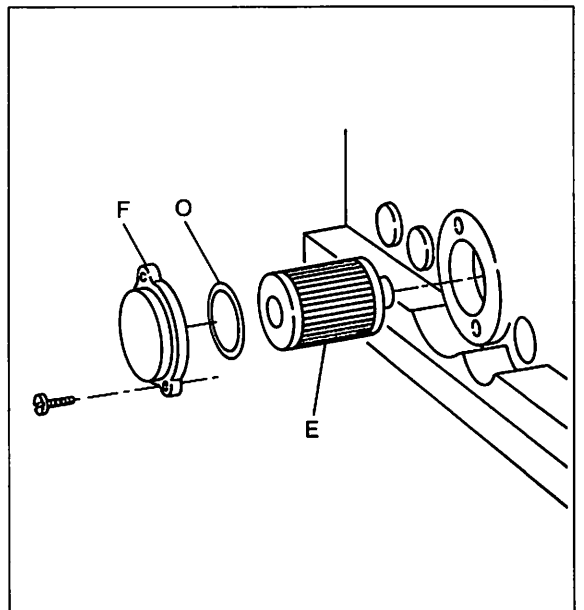



## 5. Handwheel Direction And Operating Speed

### Break In Period

For the first 200 hours of use The RX Series of machines should be run at approximately 5,000 R.P.M. This speed is approximately 15-20% below maximum speed. This is required to allow the machine to break-in before operating at full capacity.

### Pulley Direction

(Refer to Fig10)

The direction of both pulley (A) & handwheel (B) is clockwise as seen in figure 10.

Fig 10

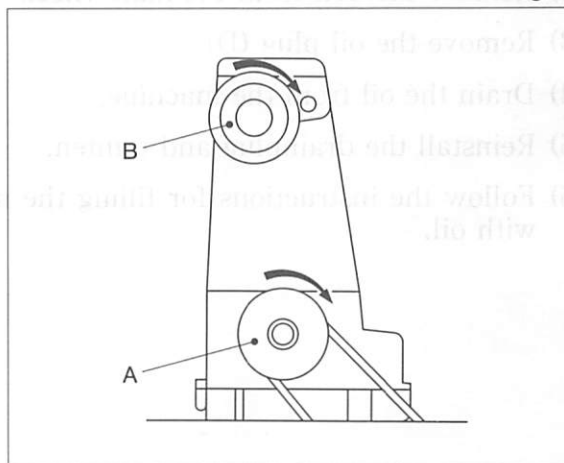

## See Below Tables For Suggested Speeds And Motor Pulley Sizes

Table 2

Model #	Maximum Speed	Suggested speed
RX-9703	6,000 R.P.M.	5,500 R.P.M.
RX-9803	5,500 R.P.M.	5,000 R.P.M.

Table 3

Pulley Diameter	Speed 50 Hz	Speed 60 Hz
80 mm	3,300 R.P.M.	3,900 R.P.M.
90 mm	3,700 R.P.M.	4,400 R.P.M.
95 mm	3,900 R.P.M.	4,600 R.P.M.
100 mm	4,000 R.P.M.	4,800 R.P.M.
110 mm	4,400 R.P.M.	5,200 R.P.M.
120 mm	5,000 R.P.M.	5,800 R.P.M.
130 mm	5,300 R.P.M.	6,200 R.P.M.
140 mm	5,800 R.P.M.	

 **MORIMOTO MFG. CO., LTD.**

**MAIN FACTORY**

180, Suna Shijohnawate-city, Osaka 575, Japan  
Tel: (0720) 77-1221 Telex: 5349134 KSPCAL-J Fax: (0720) 78-9649

**TOKYO OFFICE**

5-16-7, Kohtobashi Sumida-ku, Tokyo 130, Japan  
Tel: (03) 3635-5121 Fax: (03) 3635-5123

**OKAYAMA OFFICE**

Village Okuda 1F, 24-19, Okuba-Honmachi Okayama-city 700, Japan  
Tel: (0862) 32-9120 Fax: (0862) 22-8292

**KANSAI SPECIAL U.S.A. CORP.**

640 Gotham Parkway Carlstadt N.J. 07072 U.S.A.  
Tel: (201) 460-0350 Telex: 219449 (KSPCUR) Fax: (201) 460-1633

**MORIMOTO MFG. (H.K.) LTD.**

203-207 G/F., Lai Chi Kok Road, Sham Shui Po, Kowloon, Hong Kong  
Tel: 3-918357-9 Telex: 31167 MORHK HX Fax: 3-7891707

**MORIMOTO MFG. (H.K.) LTD. SINGAPORE REP. OFFICE**

1 Marine Parade Central #10-01 Parkway Builders, Centre Singapore 1544  
Tel: 3457576 Telex: RS25138 A/B: MMSPL Fax: 3449603

**KANSAI SPECIAL EUROPE G.M.B.H.**

Wahler Strasse 37 4000 Düsseldorf, 30 GERMANY  
Tel: 0211-658020 Telex: 8586555 KSWGD Fax: 0211-6581529

**KANSAI SPECIAL EUROPE G.M.B.H. TURKEY LIAISON OFFICE**

IMC2, Block No.2606, Unkapani, Istanbul, TURKEY  
Tel: (1)527-6230 Fax: (1)527-6317

PUB. NO. OM-RX92(E)  
PRINTED IN JAPAN